



<p>OS-299 (7-08)</p> 	<p>TRANSMITTAL LETTER</p>	<p>PUBLICATION:</p> <p>Publication 135</p>
		<p>DATE:</p> <p>October 29, 2019</p>
<p>SUBJECT:</p> <p style="text-align: center;">Inseption of Fabricated Structural Steel, 2019 Edition</p>		
<p>INFORMATION AND SPECIAL INSTRUCTIONS:</p> <p>Replace the existing Publication 135, February 2008 Edition with the attached Publication 135, 2019 Edition.</p> <p>The 2019 Edition is effective immediately.</p> <p>A description of the changes made to the 2008 Edition are listed in the attached two-page document.</p>		
<p>CANCEL AND DESTROY THE FOLLOWING:</p> <p>Older versions of Publication 135</p>	<p>ADDITIONAL COPIES ARE AVAILABLE FROM:</p> <p><input type="checkbox"/> PennDOT SALES STORE (717) 787-6746 phone (717) 787-8779 fax ra-penndotsalesstore.state.pa.us</p> <p><input checked="" type="checkbox"/> PennDOT website - www.dot.state.pa.us <i>Click on Forms, Publications & Maps</i></p> <p><input type="checkbox"/> DGS warehouse (PennDOT employees ONLY)</p>	
		<p>APPROVED FOR ISSUANCE BY:</p> <p>LESLIE S. RICHARDS Secretary of Transportation</p> <p>BY: </p> <p>Melissa J. Batula, P.E. Acting Director, Bureau of Project Delivery, Highway Administration</p>

Publication 135 Inspection of Fabricated Steel – 2019 Edition

Summary of Key Changes

General

1. Any references to out-of-date or discontinued specifications have been updated throughout.
2. References to other Publications, ASTM's and American Welding Society Codes books have been updated as required.
3. Gender Neutral compliance revisions.

Part 1 Inspection of Fabricated Structural Steel

Section I:

No significant changes.

Section II:

1. Paint sampling revised.
2. Shop Inspector's references and equipment list revised.
 - a. Electronic copies are acceptable.

Section III:

1. System Redundant Member definition and fabrication requirements added.
2. Domestic Steel Requirements clarified.

Section IV:

1. Revised coatings inspection references and clarified/detailed procedures in their entirety.

Section V:

1. Requirement added to upload coiled steel checklist into EQMS.

Section VI:

1. Added clarity for Inspection of Web Flatness.

Section VII:

No significant changes.

Section VIII:

1. Revised reporting requirements to utilize EQMS.

Part 2 Form of Inspection

Section I:

No significant changes.

Section II:

1. Added requirements for narrative heading and narrative details

Section III:

1. Clarified requirements for Fabrication Incident Reports and Quality Incident Reports

Section IV:

No significant changes.

Part 3 TR-447 and List of Forms

1. Revised example of TR-447 and sample Identification chart.
2. Removed examples of forms and replaced with list of forms that are now available on the PennDOT website.

Part 4 Standard Repair Procedures

No significant changes.

Appendices

Appendices added:

- Appendix I: Quality Control Plan Guidelines
- Appendix II: Location for Inspection Stamp
- Appendix III: Non-Destructive Test Certification Requirements
- Appendix IV: Advanced Ultrasonic Examination



pennsylvania
DEPARTMENT OF TRANSPORTATION



Publication 135 2019 Edition

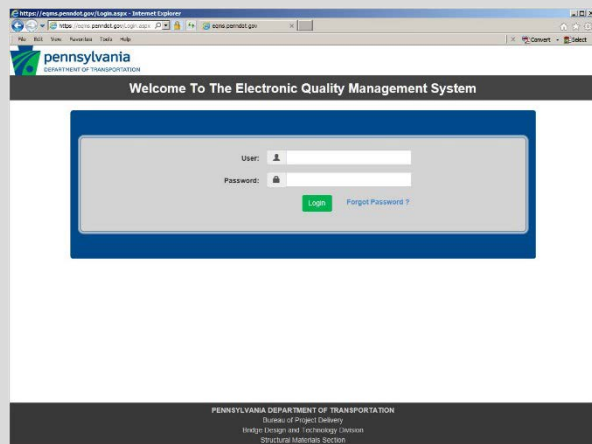

INSPECTION OF FABRICATED STRUCTURAL STEEL

[THIS PAGE IS INTENTIONALLY LEFT BLANK]

TABLE OF CONTENTS

PART 1: INSPECTION OF FABRICATED STRUCTURAL STEEL	1
SECTION I – INTRODUCTION	1
SECTION II – GENERAL REQUIREMENTS OF THE INSPECTOR.....	1
SECTION III – SHOP INSPECTION - FABRICATION INSPECTION DUTIES.....	4
SECTION IV – SHOP INSPECTION - COATINGS	6
SECTION V – INSPECTION OF INCOMING COILED STEEL	9
SECTION VI – INSPECTION WEB FLATNESS	11
SECTION VII – INSPECTION OF NEOPRENE STRIP SEAL DAM.....	12
SECTION VIII – REPORTS	12
PART 2: FORM OF INSPECTION REPORTS	13
SECTION I – EQMS TIME TRACKING REPORT	13
SECTION II – ELECTRONIC REPORTING – SHOP REPORTS.....	13
SECTION III – REPORTING	14
SECTION IV – STANDARD REPAIR PROCEDURES FOR STRUCTURAL STEEL MEMBERS.....	16
PART 3: TR-447 AND LIST OF FORMS	17
SECTION I – TR-447 INSTRUCTIONS	17
SECTION II – TR-447 SAMPLE IDENTIFICATION	19
SECTION III – LIST OF FORMS	23
PART 4: STANDARD REPAIR PROCEDURES	25
REPAIR OF BASE METAL DEFECTS FOR NON-FRACTURE CRITICAL APPLICATIONS	26
HEAT CAMBER PROCEDURE	27
HEAT SWEEP PROCEDURE	31
CORRECTING FLANGE TILT OR BEARING SQUARING	35
REPAIR OF ARC STRIKES	36
REPAIR OF GOUGES IN FLAME CUT EDGES FOR NON-FRACTURE CRITICAL APPLICATIONS	37
STIFFENER REMOVAL PROCEDURE (NON-FCM).....	39
APPENDICES	
APPENDIX I: QUALITY CONTROL PLAN GUIDELINES	42
APPENDIX II: LOCATION FOR INSPECTION STAMP	45
APPENDIX III: NON-DESTRUCTIVE TEST CERTIFICATION REQUIREMENTS	52
APPENDIX IV: ADVANCED ULTRASONIC EXAMINATION (PHASED ARRAY ULTRASONIC TESTING)	53

[THIS PAGE IS INTENTIONALLY LEFT BLANK]

PART 1: INSPECTION OF FABRICATED STRUCTURAL STEEL

SECTION I – INTRODUCTION

The purpose of this publication is to outline general guidelines for the consultant inspectors to carry out the requirements of the inspection agreement. These guidelines are generally written in the imperative mood. In imperative mood sentences, the subject “The Inspector(s)” is implied. “Shall”, “shall be” or similar words and phrases are also implied. The word “will” generally pertains to the decisions or actions of the Department and/or Structural Materials Engineer (SME) or representatives.

Details in the following sections are intended to illustrate more important and typical aspects of inspection requirements. Do not construe this as being all-inclusive. The inspection work done by the inspectors may be monitored at any time by an authorized representative of the Department. The Structural Materials Engineer (SME) or representative shall be given the opportunity to interview the Project manager and staff.

SECTION II – GENERAL REQUIREMENTS OF THE INSPECTOR

1. Work Day

Obtain advance approval from the inspection supervisor or the SME for work in excess of 7.5 hours per shift when consultant inspection is anticipated due to either occasional or extended production shifts. Take a half-hour break at a midway point during each regular shift. A shift is any continuous work period.

2. Sampling and Testing

Witness all required tests, inspections, examinations, sampling and reports; sign and date the same. Re-inspect, collect samples, and perform any special tests or reports when deemed necessary by the SME. Document your actions in the narrative fields and applicable dropdowns of the Electronic Quality Management System (EQMS) program.

Paint Sampling. When new paint lots are received for use on Department projects, ensure each fabricator/paint shop notifies the Structural Materials Section, via email to RA-pdstructmatls@pa.gov, and provides the following information:

- Manufacturer and system ID for Primer, Intermediate and Finish coats from Bulletin 15
 - Associated Lot Number(s) from the paint manufacturer
 - Quantities received
 - Copies of the CS-4171(s)

Paint sampling/testing shall be performed twice per year and as directed by the SME by each fabricator/coater. Ensure fabricator submits samples 4 weeks prior to begin coating on the project.

If a paint is to be sampled, notification will be sent by email, with instructions on which Lot Number(s) are to be sampled. To eliminate sampling errors, ‘unopened’ complete kit(s) are required. Single size containers not less than one gallon (unmixed – with each component identified and shipped separately) will be accepted. All shipping will be coordinated by and paid for by the Department.

Part 1: Inspection of Fabricated Structural Steel

3. References and Equipment

Equip each shop inspector's office with the following references and equipment: ¹

- Publication 408 (as specified in project contract) and supplements.
- Publication 135
- SSPC: Paint Application Standard No. 2 (PA-2)
- Publication 19 Field and Laboratory Testing Manual (PTM 427 and PTM 429)
- Publication 35 (Bulletin 15)
- Special Provisions (supplied by the fabricator)
- Addenda or requirements.
- AWS/AASHTO welding code(s)(Applicable year specified in Pub 408)
- Weld size and undercut gauges.
- Measuring tapes –100 ft steel tape.
- Tempel Sticks.
- Flashlight.
- Magnifying glass.
- Digital camera (specific plants, as designated by the SME)
- Other appropriate tools and equipment as specified in the contract.

Additional (paint shops)

- Dry Film thickness gauge
- Sling psychrometer
- Replica tape
- SSPC VIS comparator

Each of these references and equipment shall be supplied by the inspection agency unless otherwise noted.

4. Documentation

Maintain accurate records for each project in sufficient detail as they may be used to facilitate the investigation of defects in structures that are identified at a later date. Do not accept any material which varies from the plans, drawings, specifications or supplements without the Department's written approval of the specific variation. Do not approve any deviation from the shop drawings or shop details even when an error is suspected. Report and seek guidance from the SME in such an event.

5. Harmonious relations

Be courteous and maintain fair and harmonious relations with shop personnel while diligently attending to the required inspection activities.

¹ Electronic copies of referenced Department specifications, standards and publications are acceptable in lieu of hard copies.

Part 1: Inspection of Fabricated Structural Steel

6. Inspection Responsibilities

Table “A” illustrates the inspection roles and responsibilities.

Table A: Fabricated Structural Steel Inspection Responsibilities

Steel Fabrication Shop	
Role	Fabricate structural steel items within framework of approved quality control plan in accordance with Department specifications.
Responsibilities	<ul style="list-style-type: none"> • Fabricates in accordance with the Quality Control Plan approved by the Department. • Provides a certified Welding Inspector and other quality control personnel consistent with the level of production. • Conducts non-destructive testing, when required, in accordance with the written practice approved by the Department. • Provides quality products.
Agency Inspector	
Role	Acts as an extension of the Department. Shop operations are monitored by agency inspector performing Quality Assurance inspection.
Responsibilities	<ul style="list-style-type: none"> • Assures that fabricator is following their approved Quality Control Plan. • Assures that non-destructive testing is performed by in-house personnel or outside agencies in accordance with a PennDOT-approved NDE Written Practice. • Verifies that material incorporated in product is from approved sources. Reviews mill certifications for steel and aluminum products. • Witnesses the performance of tests and inspections by shop QC technicians. • Accepts/rejects finished item. • Attaches seal or applies stamp to accepted products at time of shipping.
Department Personnel	
Role	Department personnel oversee shops and observe the performance of agency inspectors and Quality Control activities.
Responsibilities	<ul style="list-style-type: none"> • Conducts random Independent Assurance shop inspections • Assures that agency inspectors meet contract requirements and are performing their QA inspection duties according to the contract requirements. • Samples materials, as required. • Accepts/rejects finished item • Assists in resolving fabrication related problems at project and shop.

Part 1: Inspection of Fabricated Structural Steel

Table A: Fabricated Structural Steel Inspection Responsibilities (cont.)

District / Project Engineer	
Role	Final authority for acceptance/rejection of material at project.
Responsibilities	<ul style="list-style-type: none"> • Provides Notification of Inspection form CS 430 to identify material requiring inspection, fabricator(s), locations, work breakdown structure elements (state project number) and, anticipated production dates. • Verifies that items shipped were accepted by agency inspector (seal or stamp). • Visually inspects for damaged items. • Observes unloading operations by contractor. • Assures proper storage at project site prior to use. • Accept/reject finished item. • Notifies Structural Materials Unit of unacceptable quality of work. Completes TR-800 form when applicable, to document product deficiencies.
Structural Materials Staff Engineers	
Role	Direct state-wide program to produce fabricated Structural Steel products.
Responsibilities	<ul style="list-style-type: none"> • Provides technical support for fabricated products to the Districts. • Accepts quality control plans, weld procedure specification and repairs. • Supervises plant/field inspection personnel. • Provides timely answers to steel fabricators concerning specification requirements or other request for information. • Reviews specifications updates as needed. • Works with Districts to resolve fabrication related problems.

SECTION III – SHOP INSPECTION - FABRICATION INSPECTION DUTIES

1. General duties of the inspector

- 1.1. Assure fabricator’s conformance with their quality control plan.
- 1.2. Furnish the department with the work progress on fabrication process.
- 1.3. Promptly approve acceptable materials and reject those that are unacceptable or require corrections in order to conform to specifications.
- 1.4. Assure fabricator’s conformance to a PennDOT - approved Non-Destructive Examination (NDE) written practice.

Part 1: Inspection of Fabricated Structural Steel

- 2. Verify that fabrication is in accordance with accepted shop drawings, specifications and any other contract requirements.**
 - 2.1. The specifications require accepted or accepted as noted shop drawings before fabrication. Notify the fabricator that any fabrication performed prior to receipt of the accepted or accepted as noted drawings is being performed 'at risk' and may not be accepted. Do not accept such items if they are presented for acceptance prior to receipt of the accepted shop drawings. The fabricator is not permitted to ship any fabricated items prior to receipt of accepted shop drawings.
 - 2.2. A "System Redundant Member (SRM)" requires fabrication according to the AWS Fracture Control Plan (FCP). SRM's should be designated on the design plans and shop drawings with a note to fabricate them according to AWS Clause 12.
 - 2.3. Use fabricator's shop drawings when accepted or accepted as noted shop drawings are not immediately available for items other than those in paragraph 2.1. However, note this in the project narrative. Verify previously completed work using accepted drawings when they become available.
 - 2.4. Record the heat number(s) of material used in fabrication. Record the name of the item that will be fabricated from this material (e.g. Web, flange, angle, cover plate, gusset plate, etc.)
- 3. Verify that fabrication is performed in accordance with approved welding procedures. Upload copies of the approved welding procedures used on each project into EQMS.**
- 4. Verify that shop welders are certified for each process and position used, and that copies of their certifications are on file in the inspector's office.**
- 5. Obtain and verify copies of the materials certifications, including certified mill test reports, welding materials certifications, and others as required by the specifications for all steel and other materials incorporated into the project.**
- 6. Verify that only domestic steel is used on Department projects. A mill test report with a statement: "melted and manufactured in U.S.A." Is acceptable. Direct the fabricator to obtain a certified letter from the mills furnishing steel products stating that the steel provided is melted and manufactured in the U.S. A., when mill test reports leave any doubt as to origin. Steel provided by a company with a domestic address does not guarantee that it is domestic. Acceptance of non-domestic steel supplied or incorporated must be approved by the Department. Reference Publication 408, Section 106.**
- 7. Observe the technique and performance of each welder at intervals, to make sure that they conform to the applicable AWS/AASHTO code.**
- 8. Ensure the taking of radiographs when required. Verify the joint identification and interpret the radiographs in accordance with welding and radiographic requirements of the construction contract specifications. Verify, sign and date a copy of the radiographer's report and upload the report into EQMS. The fabricator is responsible for submitting radiographs to the SME for final interpretation and retention. The inspector shall ensure that Quality Control (QC) submits the radiographs to the SME.**
- 9. Witness Ultrasonic Testing (UT) whenever possible to assure conformance with applicable specifications and code requirements. Verify, sign and date a copy of the UT Report and upload the report into EQMS.**

Part 1: Inspection of Fabricated Structural Steel

10. **Witness and approve Magnetic Particle Testing (MT) inspection after assuring conformity with contract documents. Verify, sign and date a copy of the MT Report and upload the report into EQMS.**
11. **Clearly identify each weld nondestructively tested for structures where identification on the inspection reports is inadequate to define the location or extent of each weld inspected. Prepare sketches to aid interpretation of tested welds and to eliminate any ambiguity.**
12. **Witness heat cambering and heat curving and ensure that the maximum approved temperature is not exceeded. Refer to approved procedures within this publication.**
13. **Verify reamed holes are cylindrical and not oblong and that burrs are removed. Verify that chips or drillings are removed between contact surfaces.**
14. **Verify that all spliced members and other assembled members are clearly match-marked.**
15. **Verify, witness and document rotational capacity testing, pre-installation verification testing, installation and final torque/tension verification for shop assembled bolted connections. High strength bolting is to be performed according to Publication 19 Field and Laboratory Testing Manual (PTM 427 and PTM 429).**
16. **Verify and witness all required geometric and dimensional checks have been performed by the fabricator's quality control personnel.**
17. **Unless otherwise directed, perform final inspection of each item at the time of shipment. Affix acceptance stamp on each accepted item just prior to shipment. Use indelible ink for stamping.**

SECTION IV – SHOP INSPECTION - COATINGS

1. **Inspect coated structural steel in accordance with the special provisions and/or Publication 408.**
2. **Prepare form TR-447, sample identification, for paint lot testing when instructed by the SME.**
3. **Blasting**
 - 3.1. Before blasting, verify that all edges to be coated have been rounded.
 - 3.2. Before blasting, verify that the surface temperature of the metal is at least 5°F above the dew point.
 - 3.3. Check blast profile and cleanliness of metal surface prior to coating. Document findings and test results.
 - 3.3.1. Witness all surface profile measurements taken by QC, whenever possible.
4. **Painting**
 - 4.1. Verify that paint is stored in a manner that would prevent it from exposure above or below the manufacturer's recommended temperatures.
 - 4.2. Verify that the paint has not exceeded the manufacturer's shelf life.

Part 1: Inspection of Fabricated Structural Steel

- 4.3. Immediately before painting, verify that the surface temperature is still at least 5°F above the dew point.
 - 4.4. Verify that the steel is painted within eight (8) hours of blast cleaning.
 - 4.5. Verify that the metal is not showing signs of flash rust.
 - 4.6. Verify that surface remains clean of all deleterious material immediately prior and at time of painting
 - 4.7. Whenever possible, witness the mixing and thinning of paint to verify the proper ratios according to the manufacturer's product data sheet and verify the proper paint is being applied.
 - 4.8. Verify that zinc rich paints are continuously agitated during application.
 - 4.9. Verify that striping is accomplished when specified.
 - 4.10. Verify that the paint is cured according to the contract documents and manufacturer's written instructions before additional coats are applied.
- 5. Perform and record dry film thickness readings for shop applied paint systems at the following frequency for each coat. Note that these are inspection frequencies. Ensure the fabricator meets the requirements of the specifications (refer to Publication 408, Section 1060 and the current SSPC-PA2).**
- 5.1. Non-girder applications
 - 5.1.1. Perform dry film thickness (DFT) quality assurance readings at a testing frequency equal to the cubed root of the number of individual pieces in each lot for each coat (see table below)². Perform testing on the selected pieces as painted prior to assembly.
 - 5.1.2. Take five (5) spot measurements spaced evenly, every 100 ft² of surface area painted, on each of the selected pieces³. The average of the five (5) spot measurements taken every 100 ft², shall not be less than the specified coating thickness. In addition, no single spot measurement shall be less than 80%, or above 120% of the specified coating thickness.

<u>Number of Pieces in Lot</u>	<u>Number of Samples</u>
1-2	1
3-8	2
9-27	3
28-64	4
65-125	5
126-216	6
217-343	7
343-512	8
513-729	9
730-1000	10

² Lot - A group of similar size and shape pieces for the same structure with an identical coating system that are coated in a continuous operation.

³ Spot measurement- An average of three readings in close proximity to one another.

Part 1: Inspection of Fabricated Structural Steel

5.2. Girder applications

5.2.1. Perform one complete set of DFT readings that circumscribe girders less than 100 feet in length. Two sets of reading shall be taken for girders over 100 feet long. A complete set is defined as a spot measurement taken at each one of the eight locations identified below³.

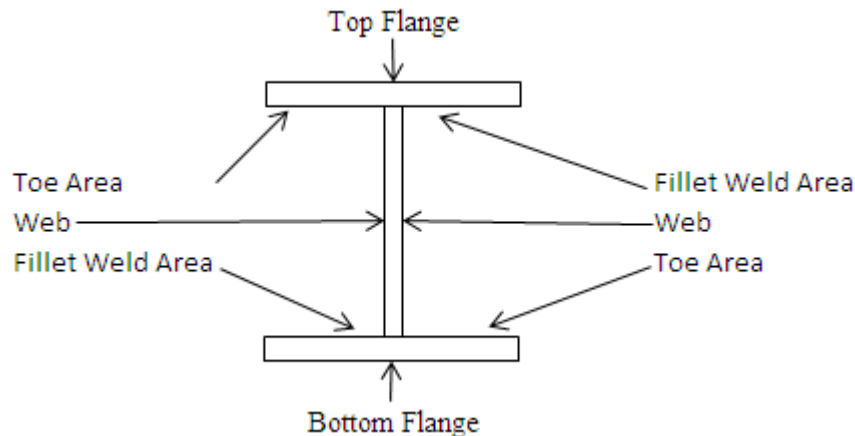

5.2.2. If one or more thickness deviations are found during initial testing, inform quality control and double the sampling/testing frequency for the suspect lot. If subsequent deviations are found, consult with the SME to determine if a quality report or fabrication incident report is required. Inform quality control of the deviations and the lot is rejected pending corrective action by the fabricator/coater.

6. Verify that the painted items are properly protected from damage during storage and shipping.

SECTION V – INSPECTION OF INCOMING COILED STEEL

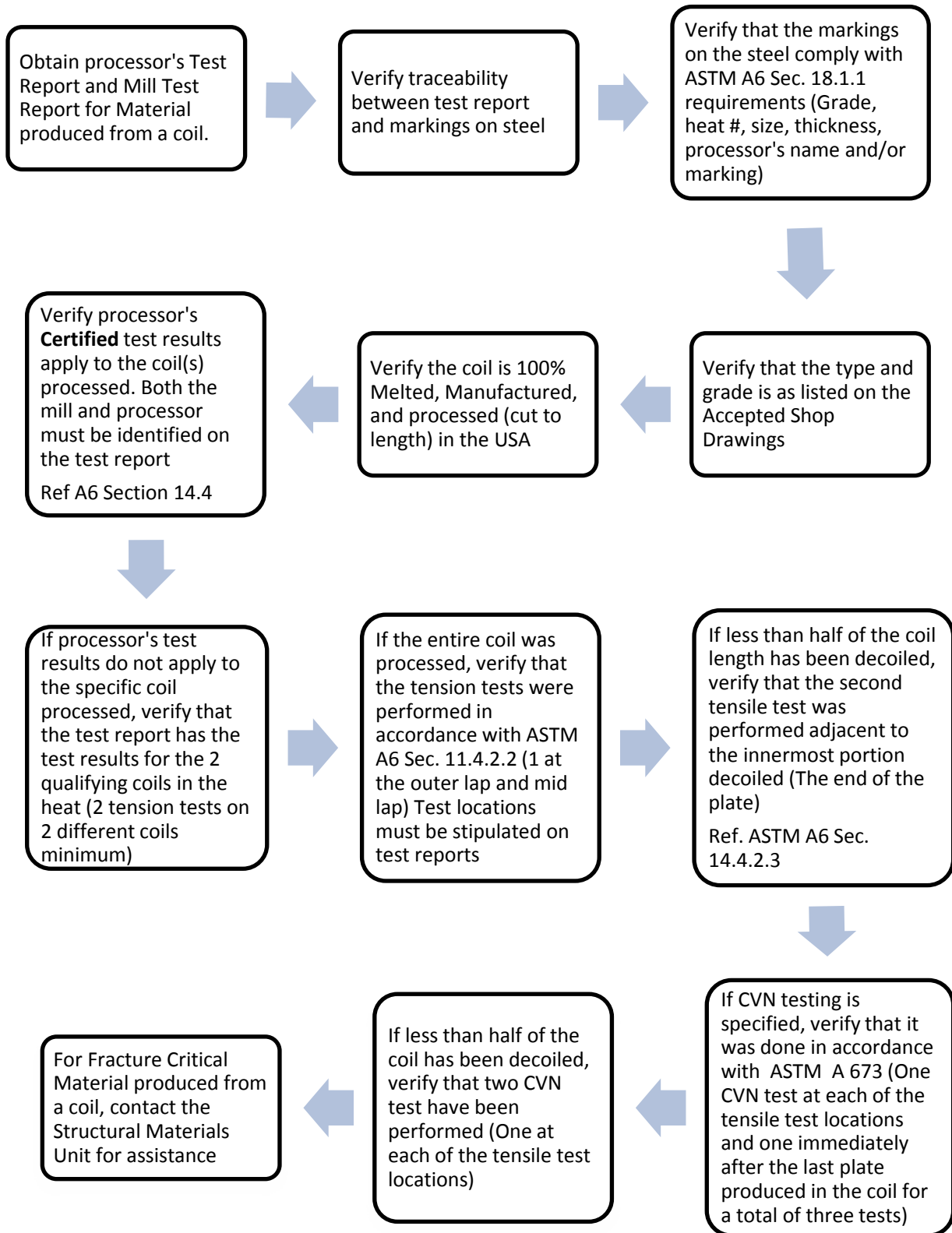

Part 1: Inspection of Fabricated Structural Steel

QA Inspectors Coiled Steel Checklist

Date: _____ Fabricator: _____

ECMS#: _____ SR: _____ Sec: _____ Plant Job #: _____

Steel Type: _____ Grade: _____ Heat #: _____

Inspection Checkpoints	Yes/No	Remarks
1) Is there traceability between test report and markings on the steel?		
2) Is processor identified by markings on the Steel?		
3) Is steel the correct type and grade as listed on the accepted shop drawings?		
4) Is the steel 100% melted, manufactured, and processed in the USA?		
6) Do the test results apply to the specific coil processed? <i>(If so, skip to question 8)</i>		
7) Have two coils, with the same heat #, been tested to qualify the coil?		
8) Are the test results for both of the qualifying coils listed on the test report?		
9) Were tension tests performed in accordance with ASTM A6 and are the locations identified?		
10) Is CVN testing required?		
11) Were three CVN tests performed?		
13) Is steel Fracture Critical?	N/A	Contact Structural Materials Unit

Is Steel Acceptable? Yes No

Inspector: _____

Note: Upload checklist and supporting documentation into EQMS

SECTION VI – INSPECTION WEB FLATNESS

Inspect web flatness in accordance with Publication 408 and AASHTO/AWS D1.5M/D1.5 Bridge Welding Code Clause 3 and C-3. The variation from flatness is the distance from the actual web surface to its theoretical location, measured normal to the plane of the theoretical web. The web face is presumed to be in its theoretical location at panel boundaries. Measurement of web distortion considers the curvature of the member and deducts the curvature arc from the actual distortion dimensions. See Figure below.

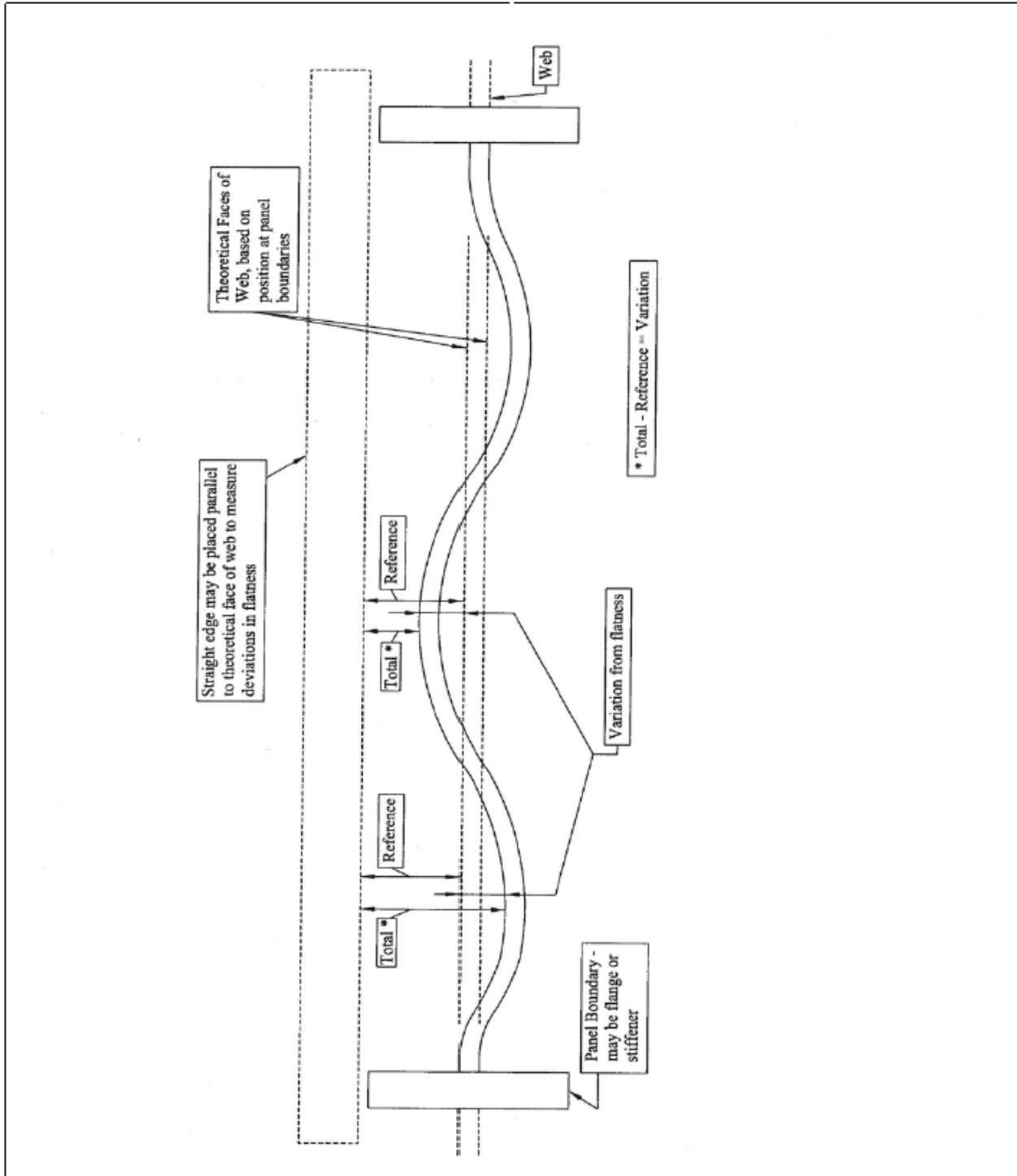

SECTION VII – INSPECTION OF NEOPRENE STRIP SEAL DAM

- 1. Inspect neoprene strip seal dams, modular expansion dams, in accordance with the accepted shop drawings. Verify the dam has been galvanized by a Bulletin 15 approved shop.**
- 2. Verify that the neoprene strip seal has been tested and approved for use by the Department.**
 - 2.1. Verify that the seal ordered and received is the style specified in the special provisions and on the drawings.
 - 2.2. The seal must be unpacked and laid out in one straight length prior to inspection.
 - 2.3. Verify that the seal is stenciled with the brand name and lot number.
 - 2.4. Verify that width is not less than or more than the nominal width by more than 5%. Verify that the measured height is within 1/4 inch of the seal's nominal height.
 - 2.5. Inspect the seal for splices, cuts, tears or other damage. Note any irregularities in size or shape. All splices in seals must have prior approval and their location must be shown on the accepted shop drawings.
 - 2.6. Prepare TR-447, sample identification, for seals and lubricants when instructed by the SME.
- 3. Verify that the dam surfaces in direct contact with the seal have been properly cleaned of all paint and foreign material before installation of seal.**
 - 3.1. Verify that the seal is thoroughly cleaned of all dirt, wax or surface bloom prior to application of lubricant-adhesive.
 - 3.2. Assure that lugs are installed at depths according to the seal manufacturer's recommendations.
 - 3.3. Verify that the seal is not stretched during installation.
 - 3.4. Verify that excess lubricant-adhesive that extrudes from the joint is removed.
 - 3.5. Direct any seal damaged during installation to be removed and replaced with a new seal.
 - 3.6. Verify that dams are properly supported for shipping.

SECTION VIII – REPORTS

All inspection activities are required to be recorded electronically using the latest version of EQMS "Electronic Quality Management System" provided by the Department. New inspectors are required to receive EQMS training according to the consultant agreement and as approved by the SME. New users are required to sign the "AGREEMENT TO AUTHORIZE ELECTRONIC ACCESS TO EQMS" prior to using EQMS.

(Note: Unauthorized use of EQMS by non-registered users will result in disciplinary action by the Department)

PART 2: FORM OF INSPECTION REPORTS

SECTION I – EQMS TIME TRACKING REPORT

Each inspector is responsible for providing a complete and accurate record of inspection activity and charges. Project specific time charges and applicable expenses must be recorded in EQMS.

SECTION II – ELECTRONIC REPORTING – SHOP REPORTS

1. General

All reporting is to be completed in EQMS unless otherwise directed. The following information is intended primarily to provide general guidance in describing the reporting functions in EQMS and the Department's direction for your role in providing Quality Assurance inspection. This information is not intended to replace the specific instruction provided in the User Guide/Help Topics of EQMS.

2. Narrative

There are two narrative types in EQMS – Plant Narratives and Project Narratives.

Plant narratives are those activities which are general in nature and do not pertain specifically to an individual inspector or which pertain to all projects. Examples may include equipment calibrations reviewed, description of visitors, etc. The Project narrative is a description of those activities associated only with a specific project.

Narratives are expected to be brief and concise but must provide a basic accounting of the quality assurance oversight activities performed or witnessed, not just a recordation of deficiencies. For example:

- **At the beginning of the Narrative include the following:**
 - **Inspector's name**
 - **Date**
 - **Start and End Times.**
- **Include justification/reasoning for overtime worked.**
- Describe the major items of inspection during the period of inspection. Indicate which items were performed in accordance with contract documents and specifications.
- Identify any problem(s) and the action(s) taken or desired. Follow-up on problems previously reported until resolved. Note final dispositions.
- Note attached correspondence, indicating date received, if appropriate.
- Note when shop drawings are not accepted. Follow-up daily until they are accepted.
- Note when unapproved welding procedures are being used.
- Note any change in welding procedures, requalification or qualification of new welders.
- Note when Department approved repairs are performed.
- Note when inspection for stored materials payment is performed.
- Note when materials are sampled.

Part 2: Form of Inspection Reports

SECTION III – REPORTING

1. Material samples (TR-447)

Complete the material samples form, in EQMS, for every TR-447 sent to PennDOT Laboratory Testing Section (LTS). Periodically check status of sampled materials using EQMS. Notify fabricators of the disposition of sampled materials.

2. Fabricated items

Complete project status record using EQMS. Complete for each type of production utilizing all fields which are applicable.

2.1. Bearing status record:

2.1.1. Identify the type and piece mark.

2.1.2. Enter the inspector's initials under each piece mark for each activity and date of inspection.

2.1.3. Record the weight of each piece mark shipped.

2.2. Girder fabrication project status record:

2.2.1. Identify the piece mark.

2.2.2. Record the inspector's initials under each piece mark for each activity and date of inspection.

2.2.3. Record the weight of each piece mark shipped.

2.3. Stringer fabrication project status record:

2.3.1. Identify the piece mark.

2.3.2. Record the inspector's initials under each piece mark for each activity and date of inspection.

2.3.3. Record the weight of each piece mark shipped.

2.4. Steel sign structure – pole project status record:

2.4.1. Identify the item, type and piece mark.

2.4.2. Record the inspector's initials under each piece mark for each applicable activity and date of inspection.

2.4.3. Record the weight of each piece mark shipped.

2.5. Expansion dams status record form:

2.5.1. Identify the item, type and piece mark.

2.5.2. Record the inspector's initials under each piece mark for each applicable activity and date of inspection.

2.5.3. Record the weight of each piece mark shipped.

Part 2: Form of Inspection Reports

2.6. Fabrication status record for secondary items:

2.6.1. Record the fabrication status for the items listed below:

- Drainage Items
- Grid Flooring
- Posts
- Railings
- Pilings
- Miscellaneous (Diaphragm, Truss Members, Pier Caps, Utility Support, Cross Frames, Diagonal Bracing and Steel Plate)

2.6.2. Identify the item, type, piece mark and quantity.

2.6.3. Record the inspector's initials under each piece mark for each applicable activity and date of inspection.

2.6.4. Record the weight of each piece mark shipped.

3. Quality Reports and Fabrication Incident Reports

This procedure is intended to address the intent of and justification for issuance of quality reports and fabrication reports. The inspector is directed to consult with the SME prior to issuing a quality report or fabrication incident report.

Fabrication Reports and Quality Reports are issued to provide written notification to the fabricator of a product or procedural deviation. The conditions for issuing a Fabrication Report differ from a Quality Report as illustrated below. **The consultant inspector shall seek direction from the SME to determine if a Quality or Fabrication Incident Report is required.**

3.1. Fabrication Report

A Fabrication Report should be issued to the Plant Quality Control Manager when the following conditions are met:

- Continued poor Quality of Work, requiring repair
- Quality Control plan deviations
- Minor specification deviations which do not affect product acceptability or performance
- Fabrication Reports should NEVER be issued when the product specification deviation would prevent acceptance. For these circumstances, a Quality Report must be issued.

Fabrication Reports must be completed and resolved in a timely manner. The inspector is responsible for documenting the discrepancy, the fabricator's response and the fabricator's corrective action in EQMS. Continued quality control violations or specification deviations, however minor, will not be permitted to persist. Bring repetitive quality issues or outstanding deviations to the attention of the SME for further action.

Part 2: Form of Inspection Reports

3.2. Quality Report

A Quality Report shall be issued to the Plant Quality Control Manager when the following conditions are met:

- Fabrication which is not in accordance with the accepted drawings.
- Shipment of unapproved /unstamped material.
- Significant specification deviations which render the material unacceptable.
- Other areas, as defined in the Quality Report
- Persistent quality related issues which have not been corrected.

Quality Reports must be completed and resolved in a timely manner. The inspector is responsible for documenting the discrepancy, the fabricator's response and the fabricator's corrective action in EQMS

SECTION IV – STANDARD REPAIR PROCEDURES FOR STRUCTURAL STEEL MEMBERS

The included procedures are to be used for common repairs on non-fracture critical members. Ensure the repair conditions exactly match the procedure. Ensure any modifications to the procedure is submitted to the Structural Materials Engineer for evaluation and acceptance prior to the start of work (see PART 4).

PART 3: TR-447 AND LIST OF FORMS

Note: This part does not contain a comprehensive list of inspection forms. Inspection documentation is to be entered directly into EQMS, whenever applicable. The following list of forms is for reference use only. The most current versions are located as links in EQMS and on the PennDOT website.

SECTION I – TR-447 INSTRUCTIONS

1. Sample Identification

Complete a hardcopy TR-447 for all samples sent to the PennDOT Laboratory Testing Section. Immediately forward a copy of the form to the SME via facsimile or scanned adobe file via e-mail to: RA-pdSTRUCTMATLS@pa.gov.

2. Filling out a TR-447

Refer to Part 3 of PUB 135 for a sample TR-447.

- 2.1. **Material Code:** Material Codes are listed in Part 3.
Example: 414
- 2.2. **Material Class:** Material Classifications are listed in Part 3.
Example: 50LAM
- 2.3. **Date Collected:** The date the sample was collected from the fabricator.
Format: MMDDYYYY
Example: 07312007
- 2.4. **Contract Number:** The Contract Number is the same as the ECMS number. If the project does not have an ECMS number leave the Contract Number field blank.
Example: E034567
- 2.5. **State Project Number (SPN):** The SPN is listed in EQMS under the Contract Number.
Example: 0-03012-0-7-001-0930-375-**9405**
(Note: The cost function is always **9405** for samples sent to the lab for testing)
- 2.6. **Sample Classification:** The Sample Classification is always **QR**.
- 2.7. **Supplier Code:** Supplier Codes are listed in Bulletin 15 next to the manufacturer's address.
Example: **BROWD 15**
(Note: The number '**15**' must be added to the end of every Supplier Code)
 - 2.7.1. If the material is taken on certification and the supplier is not listed in Bulletin 15, the supplier code is **NOBULL15**.
- 2.8. **408 Year-Section:** The year and section number of the specification used to test the material from Pub 408. Leave blank if unsure of the 408 Year and Section.
- 2.9. **Total Inc:** Number of samples being submitted with the TR-447.
- 2.10. **Lot Number:** The lot number assigned to the product by the manufacturer. If lot number is more than 10 characters long, leave this field blank and write it in the Remarks.

Part 3: TR-447 and List of Forms

- 2.11. **Lot Size/ Quantity:** Number of pieces, square footage and/or pounds in the lot.
- 2.12. **Location Code:** The location code, of the fabricator, where the sample is pulled. Location codes are listed in Bulletin 15 next to the fabricators address (The Location Code is the same as the fabricator's Supplier Code).
- Example: **BROWD 15**
(Note: The number '15' must be added to the end of every Location Code)
- 2.13. **Place Collected:** The city and state where the sample is collected.
- 2.14. **Sampled By:** Inspector's name.
- 2.15. **Telephone Number:** Inspector's telephone number.
- 2.16. **Remarks:** Any extra information such as the size of the sample, type of material and/or name of the supplier if not in Bulletin 15.
- Example: 1 sheet 2% carbon filled PTFE, ¼" thick etched one side
- 2.17. **Peel-off Bar Code Stickers:** Place a peel-off bar code sticker on all increments associated with the TR-447.

3. Special Sampling Instructions:

- 3.1. **Paint Sampling:** Fill out a TR-447 (hard copy or electronic as specified by the SME) as required for the paint system being sampled.
- 3.2. **High Strength Bolt Assembly Sampling:** Fill out a TR-447 for each part of the bolt assembly (Bolt, Nut and Washer) and also one for the complete bolt assembly (Four TR-447's total for each Rotational Capacity Lot).
- 3.3. **Plain and Laminated Neoprene Bearing Pads (Pub 408, Section 1113):** Sample bearing pads in accordance with Publication 19 Field and Laboratory Testing Manual (PTM 312) when directed by the Structural Materials Engineer.
- 3.4. **Pot Bearing Elastomeric Disc Sampling (Pub 408, Section 1111):** Use Material Code 414 and Material Class 50POT. Indicate the sample is a Pot Bearing Disc, under the remarks, on the TR-447.
- 3.5. **Disc Bearing Polyether Urethane Sampling (Pub 408, Section 1111):** Use Material Code 414 and Material Class DISC. Indicate the sample is a Disc Bearing, under the remarks, on the TR-447.
- 3.6. **PTFE (Teflon) Sampling:** On the TR-447 indicate the type of material (Filled or Unfilled) and the ASTM it was made in accordance to. For Filled PTFE, indicate the type and percentage of filler material used.

SECTION II – TR-447 SAMPLE IDENTIFICATION

PUBLICATION 408 SECTIONS AND/OR OTHER APPLICABLE AREAS	DESCRIPTION	MATERIAL CODE	MATERIAL CLASS	
1060.2 CLASSIFIED ACCORDING TO APPLICATION ORDER	STRUCTURAL PAINT	306	PRIME TOP	INTER DRYFLM
1111.02(b)1 & 1111.02(b)2	POT BEARING DISC BEARING	414	50POT DISC	
1111.02(c)5, 1111.02(c)6, & 1111.02(c)7	TEFLON	520	FILLED	UNFILL
1113.03(f) 50 & 60 DURO. PLAIN & LAMINATED BEARING PADS	BEARING PAD – NEOPRENE <i>PL = plain, LAM = laminated</i>	414	50PL 60PL	50LAM 60LAM <u>Note:</u> Blank Material Class used for Misc. Bearing Pad
1113.03(h) MATERIAL IS CLASSIFIED ACCORDING TO TYPE SPECIFIED.	BRIDGE SHOE BEDDING	426	TYPEI	TYPEII
THIS CODE IS TO BE USED FOR ALL ALUMINUM BOLTS, NUTS, WASHERS & MISCELLANEOUS HARDWARE USED IN A STRUCTURAL APPLICATION	STRUCTURAL FASTENERS – ALUMINUM	246	BOLT WASHER	MISCHW NUT <u>Note:</u> Blank Material Class used for Misc. Fasteners
THIS CODE IS TO BE USED FOR ALL ALUMINUM BOLTS, NUTS, WASHERS & MISCELLANEOUS HARDWARE USED IN HIGHWAY LIGHTING.	HIGHWAY LIGHTING FASTENERS – ALUMINUM	247	BOLT WASHER	MISCHW NUT
THIS CODE IS TO BE USED FOR ALL STEEL BOLTS, NUTS, WASHERS & MISCELLANEOUS HARDWARE USED IN HIGHWAY LIGHTING	HIGHWAY LIGHTING FASTENERS - STEEL	255	BOLT WASHER	MISCHW NUT
THIS CODE IS TO BE USED FOR ALL BOLTS, NUTS, WASHERS & MISCELLANEOUS HARDWARE USED IN GUIDE RAIL.	GUIDE RAIL FASTENERS	257	BOLT WASHER	MISCHW NUT
THIS CODE IS TO BE USED FOR ALL STEEL BOLTS, NUTS, WASHERS & MISCELLANEOUS HARDWARE USED IN A STRUCTURAL APPLICATION	STRUCTURAL FASTENERS - STEEL	259	BOLT WASHER	MISCHW NUT DTI <u>Note:</u> Blank Material Class used for Misc. Fasteners

Part 3: TR-447 and List of Forms

THIS CODE IS TO BE USED FOR WELDERS CERTIFICATIONS & FOR BRIDGE STEEL SAMPLES, BASED ON CROSS-SECTIONAL SHAPE	BRIDGE STEEL <i>RECT = rectangular</i>	261	ROUND RECT Note: Blank Material Class used for Misc. bridge Steel
MATERIAL CLASSIFIED BY TYPE OF ANCHOR. EPOXY IS USED TO ANCHOR BOLTS OR DOWELS.	ANCHOR BOLT - STEEL	265	WEDGE HOOK EPOXY TIE WIGGLE DROPIN
PDT SPECIAL PROVISION FOR WATER PROOFING MEMBRANE	WATERPROOFING MEMBRANE	510	WPM TROUGH HDM
705.4(d) PREFORMED NEOPRENE COMPRESSION SEALS FOR BRIDGE JOINTS	NEOPRENE BRIDGE SEAL	423	COMP STRIP

Part 3: TR-447 and List of Forms

Shelf Life Expiration Date: 10/30/19

S-37006 8-1/2 x 14-1/8"; Pt 1; Front; PMS 470; 5/8" linehole stub at top; horiz. perf at 11-3/8" from top

A742452



TR-447 (9-17)

SAMPLE IDENTIFICATION

LTS USE ONLY

Lab Serial Number

Mett Code	Material Class	S Class	Lab Serial Number

A742452

Aggregate Usage by Sect 703 Table D	Lot/Batch Number	Lot/Batch Size & Units

Location Code	Place Collected	Date Collected	# of Inc	Related Sample
		M M D D Y Y Y Y		A

Tank #	Construction Item #	PE/PCQ	Product Name

WORK BREAKDOWN STRUCTURE (WBS)												
Contract Number	MP	S	SR or W/O	Sp	P	Sec						Supplier (Party) Code
F	-	-	-	-	-	-	-	-	-	-	-	

Pub 408 Year	Ver.	Section	Special Provision	PG Number
			<input type="checkbox"/> Yes	

Sampled By

Title	First Name	Middle Name	Last Name / Suffix
	Phone Number	Ext.	Certification ID
	Consultant <input checked="" type="checkbox"/>	Contractor <input checked="" type="checkbox"/>	Manufacturer <input checked="" type="checkbox"/>
	PennDOT Employee <input checked="" type="checkbox"/>	Producer <input checked="" type="checkbox"/>	Other <input type="checkbox"/>

Inspected By









Title	First Name	Middle Name	Last Name / Suffix
	Phone Number	Ext.	Certification ID
	PennDOT Employee <input checked="" type="checkbox"/>	Consultant <input checked="" type="checkbox"/>	Other <input type="checkbox"/>

INCREMENT INFORMATION											
Inc	County	SR	Segment	Offset	Section	Station	GTR Offset	LR	Placement Date	AASHTO T 208	
1											
2											
3											
4											
5											
6											
7											

JMF		Design		Concrete			Self Consolidating Concrete		
Year	Number	Thickness		Air	Slump	Temp	J-Ring	Slump Flow	VSI

Remarks:

LAB

 A742452-1	 A742452-2	 A742452-3
 A742452-4	 A742452-5	 A742452-6
 A742452-7	 A742452-8	 A742452-9

SAMPLE CLASSIFICATION

District Quality Assurance (DQ) - Samples either lifted by District QA inspectors and sent to the Lab for testing or tested in the field by the District QA inspector (applies only to Districts that have QA samples.)

Investigation (IV) - Sample submitted for retest to investigate prior sample failure. Investigation sample I.D. must reference original sample I. D.

Information (IF) - Samples submitted to the central Lab at the discretion of the District personnel. The results are not used for acceptance.

Field Verification (FV) - A verification sample taken at the project that is sent to the Lab for testing.

Acceptance (AS) - District acceptance test sample which influences payment to contractors.

Quality Assurance (QA) - Samples lifted by Central Office QA engineers and Inspectors and sent to the Lab for testing.

Preliminary (PS) - Samples tested prior to the qualification testing for Bulletin 14.

Qualification (QS) - Samples provided by producers as part of the process of listing them in Bulletin 14.

Requalification (RS) - Samples provided by producers as part of the process of maintaining their listing in Bulletin 14.

Product Evaluation (PE) - Samples submitted for a new product. Product Evaluation and Qualification (PEQ) samples are required to be submitted prior to Inclusion of the product In a Bulletin.

Plant Verification (PV) - A verification sample taken at the plant that is sent to the Lab for testing.

External (ES) - Any sample which does not directly pertain to state funded highway projects or state qualification of producers. These samples may come from municipalities, Turnpike, DER, etc.

Quality Review (QR) - Samples taken from prestressed/precast concrete and fabricated structural steel plants as part of the Structural Materials Quality Assurance process.

Quality Assurance Witnessed (QW) - Results of tests that are witnessed by a QA engineer or inspector.

Research (RE) - Testing done for research which is not part of the deviation tracking or qualification processes.

Quality Assurance Field Test (QF) - Samples tested in the field by the QA engineer or Inspector.

District Witnessed (DW) - Results of tests that are witnessed by District inspectors.

District Field Test (DF) - Results of tests performed by District inspectors.

Independent Assurance (IA) - Independent Assurance split samples lifted by Central Office QA engineers and inspectors with one of the splits sent to the Lab for testing.

Structural Review (SR) - Informational samples taken from prestressed/precast concrete and fabricated structural steel plants.

SECTION III – LIST OF FORMS

- TR-50 PRODUCTION JOINT WELDING PROCEDURE SPECIFICATION
- TR-51 ALUMINUM PRODUCTION JOINT WELDING PROCEDURE SPECIFICATION
- TR-52 PRODUCTION JOINT WELDING PROCEDURE SPECIFICATION
- TR-53 FILLET WELD SOUNDNESS TEST (FWST)
- TR-54 ALUMINUM WELD PROCEDURE QUALIFICATION RECORD
- TR-55 PROCEDURE QUALIFICATION RECORD
- CS-110 PAYMENT AUTHORIZATION FOR MATERIAL STORED OR ON HAND

[THIS PAGE IS INTENTIONALLY LEFT BLANK]

PART 4: STANDARD REPAIR PROCEDURES

The included procedures are to be used for common repairs on non-fracture critical members. Ensure the repair conditions exactly match the procedure. Ensure any modifications to the procedure is submitted to the Structural Materials Engineer for evaluation and acceptance prior to the start of work. Standard repair procedures outline acceptable repair procedures that do not require review and acceptance by the SME prior to performing the repair. These procedures need to be completed and signed by the inspector and plant QC representative before completing the repair. Scan and attach the completed report to your EQMS narrative.

Part 4: Standard Repair Procedures

08/19

REPAIR OF BASE METAL DEFECTS FOR NON-FRACTURE CRITICAL APPLICATIONS

Fabricator Name: _____ ECMS #: _____

SR: _____ Sec: _____ County: _____ S- _____

Date: _____ Location on Piece: _____

The following procedure shall be utilized to repair base metal defects on rolled surfaces within the limitations of the applicable AWS D1.5 and ASTM A6 Specifications

1. Grind to bright metal to remove the defective area. The excavation shall be smooth and free of irregularities.
2. Excavations shall be made with a minimum ¼-inch bottom radius. The sides shall slope at a minimum 20-degree included angle and the ends shall slope back at a 45-degree minimum. Attach run-off tabs when necessary. Tack welds are not permitted outside the weld area.
3. Magnetic Particle test the area to assure removal of all discontinuities. Inspect both parallel and perpendicular to the length of area to be repaired.
4. Weld the defect with a qualified welder, using an approved Weld Procedure Specification. Grind weld flush with surrounding base metal. Grind parallel to the direction of applied stress.
5. Ultrasonic and Magnetic Particle inspection shall be performed as per the applicable sections of AWS D-1.5. Radiographic inspection, in lieu of UT, is required if adjacent holes, appurtenances, etc. preclude acceptable UT inspection
6. All work shall be performed in the presence of a representative of the Pennsylvania Department of Transportation and the fabricator’s Quality Control personnel.

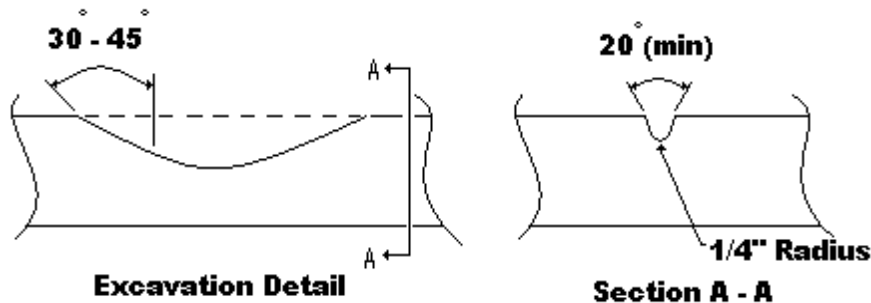

Fabricator’s Quality Control Representative

PennDOT Inspector Witnessing Procedure

Signature: _____

Signature: _____

Part 4: Standard Repair Procedures

08/19

HEAT CAMBER PROCEDURE
(Rolled Beams and Welded Girders*)

Fabricator Name: _____ ECMS #: _____

SR: _____ Sec: _____ County: _____ S- _____

Date: _____ Location on Piece: _____

The following heat cambering procedure shall be used for material with a specified yield strength not greater than 50,000 psi. The heating temperature shall not exceed 1150 °F as controlled by temperature indicating crayons.

* NOTE: For welded girders, cut the web to the prescribed camber with suitable allowance for shrinkage due to cutting, welding and heat curving. Camber correction by heating shall be limited to twice the allowable tolerance from the as-planned camber. Heat cambering of rolled beams in excess of 8 inches is not permitted.

Material Specification: ASTM A709 Grade 36, 50 & 50W
Heat Source: Oxy-fuel Heating Torch
Fuel Gas: Optional
Technique: V-Heating
Single or Multiple Torch: Cambering: Single or Multiple
Heating Temperature: 1000-1150 °F

1. Before heating begins, members to be cambered shall be supported with the web vertical. The flange which will be concaved after cambering shall be placed upward. The member shall also be supported or braced in such a manner as to prevent the member from overturning. Appropriate blocking, as required, shall be used to attain the required tolerance and to prevent excessive movement. (See Sketch #1 for blocking details). Camber tolerances shall be specified by the applicable code and contract specifications i.e. AWS D1.5-Section 3.5, unless otherwise specified. Camber members before heat curving.
2. Heat cambering shall be performed using triangular “V” heating patterns. The heating patterns shall be spaced and marked throughout the length of the member as required to provide the specified camber. (See Sketch #2 for details of the required heating pattern.) Heating shall be performed using an approximately one-inch multi-orifice rosebud tip. Fuel for heating shall be an oxygen-fuel combination. Rosebud tip selection shall be made to promote heating efficiency while minimizing distortion and excessive heating in the web.
3. V-heating shall begin at the apex of the heating pattern. The temperature shall be raised to between 1000 °F and 1150 °F as rapidly as possible and progress slowly toward the top of the heating pattern. As heating progresses toward the top of the V, the heating torch shall not be returned to the apex of the heating pattern or to a previously heated

Part 4: Standard Repair Procedures

area. Heating may be performed either from one side of the web using one torch, or from both sides of the web using two torches. Heat shall not be applied to any previously heated areas on the member.

4. During application of the heat, the heating torches shall be manipulated in a manner as to guard against general and surface overheating. When heating thick material, it may be necessary to occasionally interrupt heating for periods of less than one minute to allow the heat to soak into the material and avoid over-heating. At a minimum, temperature indicating crayons for 600, 1000, and 1150 °F shall be supplied for verification of the material temperature. Any heating that results in a steel temperature in excess of 1150 °F shall be considered destructive and be cause for rejection of the steel. Steel rejected for overheating may be investigated for acceptance, repair, or replacement by means as directed by the Engineer. The cost of the investigation shall be borne by the fabricator.
5. After heating is complete, the member shall be allowed to cool naturally. Artificial cooling using dry compressed air only may be performed after the material has cooled to 600 °F. Magnetic Particle testing required for the beam or girder shall be performed after all heat cambering is completed.
6. All work described above shall be witnessed by PENNDOT inspector and the fabricator's Quality Control personnel. Work shall be performed in accordance with AWS D1.5-, AASHTO and the contract specified Publication 408 revision.

Fabricator's Quality Control Representative

PennDOT Inspector Witnessing Procedure

Signature: _____

Signature: _____

Part 4: Standard Repair Procedures

SKETCH #1

BLOCKING DETAIL

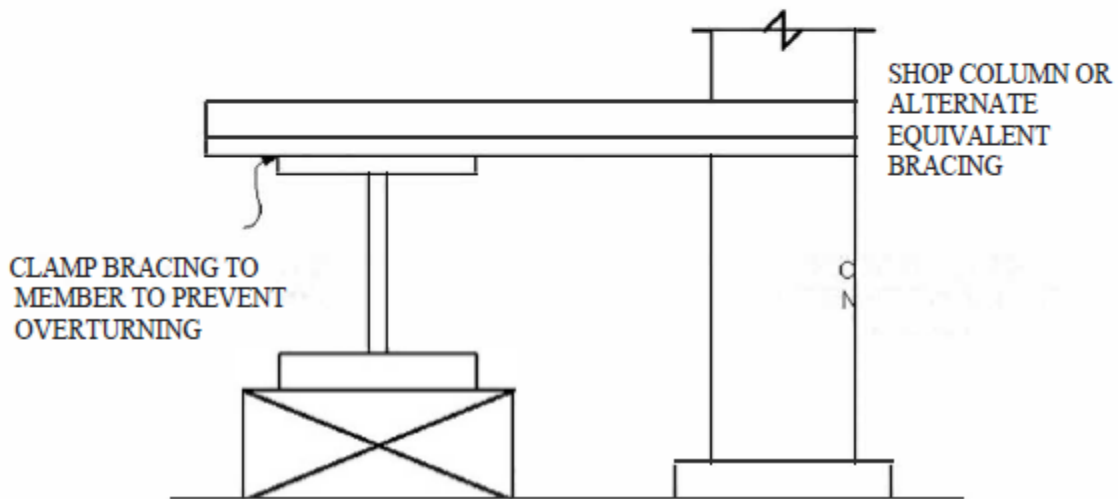
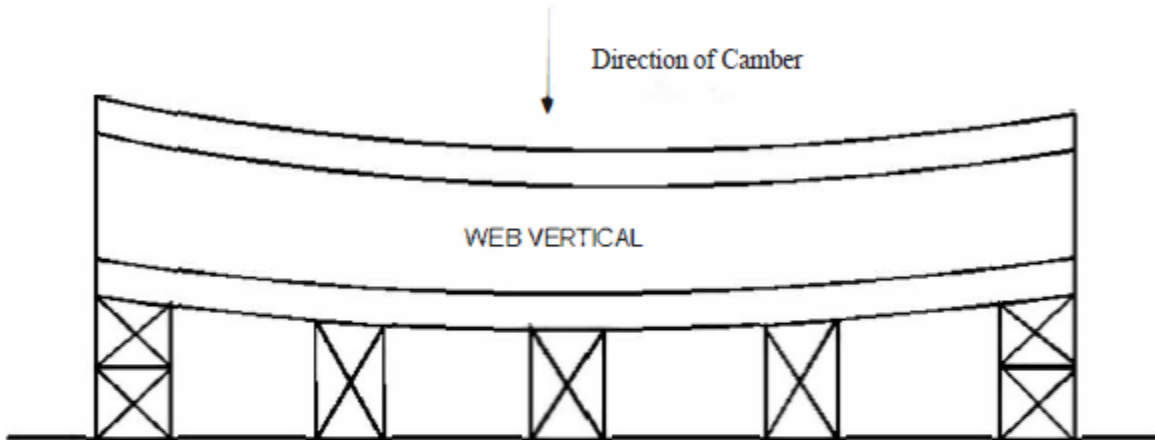

SKETCH# 2

V-TYPE HEATING PATTERN DETAIL

DETAIL 1 : To be used for cambering

A = 20 degree max

B = 2/3 Girder/Beam depth min.

C = 1" min.

D = 10" max.

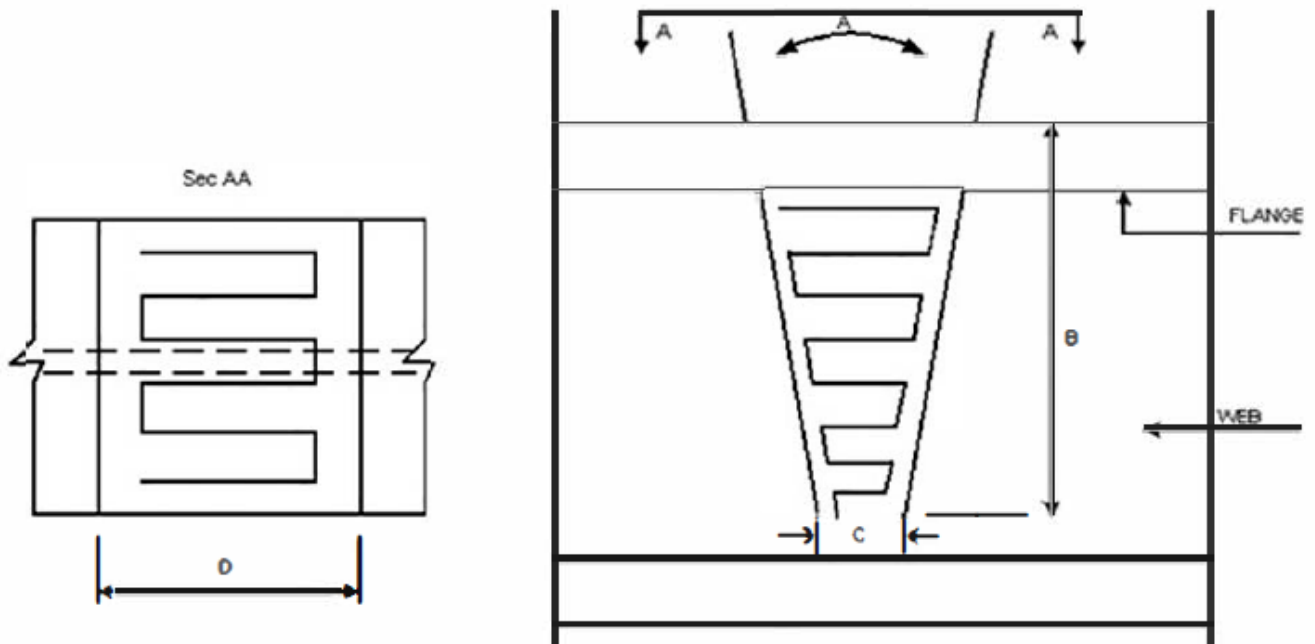

Part 4: Standard Repair Procedures

08/19

HEAT SWEEP PROCEDURE
(Rolled Beams and Welded Girders)

Fabricator Name: _____ ECMS #: _____

SR: _____ Sec: _____ County: _____ S- _____

Date: _____ Piece Mark: _____ Radius: ≥ 1000 ft < 1000 ft

The following heat sweep procedure shall be used for material with a specified yield strength not greater than 50,000 psi. The heating temperature shall not exceed 1150 °F as controlled by temperature indicating crayons.

Material Specification:	ASTM A709 Grade 36, 50 & 50W
Heat Source:	Oxy-fuel Heating Torch
Fuel Gas:	Optional
Technique:	V or Strip Heating
Single or Multiple Torch:	Single or Multiple
Heating Temperature:	1000-1150 °F

1. Heat member with the web in the vertical position.
2. Before heating begins, brace or support the member in such a manner that the tendency of the girder to deflect laterally during the heat-curving process will not cause the member to overturn. Appropriate blocking, as required, shall be used to attain the required tolerance and to prevent excessive movement. Sweep tolerances shall be specified by the applicable code and contract specifications, unless otherwise specified. Camber members before heat curving. Heat shall be applied to adjust the member's sweep to meet contractual requirements.
3. Members shall be heat-curved prior to the attachment of end bearing stiffeners, lateral gusset plates, longitudinal stiffeners, welding of intermediate stiffeners and connection plates to the flanges, or painting. Longitudinal stiffeners are required to be heat curved or cut to the required radius prior to being welded to the curved member.
4. Heat application shall be by single or multiple orifice tips only. The size of the tip shall be proportional to the thickness of the heated material. Fuel for heating shall be an oxygen-fuel combination. Tip selection shall be made to promote heating efficiency while minimizing distortion and excessive heating in the member. Heat **shall not** be applied to previously heated areas. As a guide, the tip sizes shown in Table 1, are recommended.
5. Curve members by either continuous or V-type heating. For the continuous method, heat a strip or intermittent strips along the edge of the top and bottom flange in an essentially simultaneous manner depending on flange widths and thickness; use a strip of sufficient width and temperature to obtain the required curvature. For the V-type heating (See sketch 1), heat the top and bottom flanges in truncated triangular or wedge-shaped areas having

Part 4: Standard Repair Procedures

their base along the flange edge and spaced at regular intervals along each flange; using spacing and temperature as required to obtain the required curvature, and to allow heating to progress along the top and bottom flanges at approximately the same rate. For both types of heating, heat the flange edges that will be on the inside of the horizontal curve after cooling. Heat both the inside and outside side flange surfaces if the flange thickness is 32 mm (1 1/4 inches) or greater. Heat the two surfaces concurrently.

6. For the V-type heating, terminate the apex of the truncated triangular area applied to the inside flange surface just before the junction of web and the flange is reached. To avoid unnecessary web distortion, take special care when heating the inside flange surface (the surface that intersects the web) so that heat is not applied directly to the web. When the radius of curvature is 1000 feet or more, extend the apex of the truncated triangular heating pattern applied to the outside flange surface to the juncture of the flange and web. When the radius of curvature is less than 1000 feet, extend the apex of the truncated triangular heating pattern applied to the outside flange surface past the web for a distance equal to one-eighth of the flange width or three inches, whichever is less. For the truncated triangular pattern, provide an included angle of approximately 15 to 30 degrees, but do not exceed 10 inches for the base of the triangle. The flange edges to be heated are those that will be on the inside of the horizontal curve after heating. The heating torch shall not be returned to the apex of the heating triangle after heating has progressed toward the base.
7. Heating shall be confined to the planned and marked patterns. The steel shall be brought to a temperature between 1000 °F and 1150 °F as rapidly as possible. Temperature indicating crayons manufactured to indicate 600, 1100 and 1150 °F shall be utilized. All heat measurements shall be taken after the torch has been removed from the steel. Any heating that results in a steel temperature in excess of 1150 °F shall be considered destructive and be cause for rejection of the steel. Steel rejected for overheating may be investigated for re-acceptance, repair, or replacement by means as directed. The cost of the investigation shall be borne by the fabricator.
8. Quenching with water or a combination of air and water is not permitted. Cooling with dry compressed air is permitted after the steel has been allowed to cool naturally to 600 °F.
9. Magnetic Particle testing required for the girder shall be performed after all heat cambering is completed. All nondestructive tests to evaluate damage and any corrective work ordered by the owner to compensate for overstressing shall be performed by the fabricator at no additional cost to the owner.
10. All work described above shall be witnessed by PENNDOT inspector and the fabricator's Quality Control personnel. Work shall be performed in accordance with AWS D1.5-, AASHTO and the contract specified Publication 408 revision.

Fabricator's Quality Control Representative

PennDOT Inspector Witnessing Procedure

Signature: _____

Signature: _____

SKETCH# 1

CONTINUOUS HEATING PATTERN DETAIL

L = Full length of member or intermittent lengths as required to obtain the specified curvature.

W = 1" to 2"

Note: Heating of the top & bottom flanges shall be performed simultaneously.

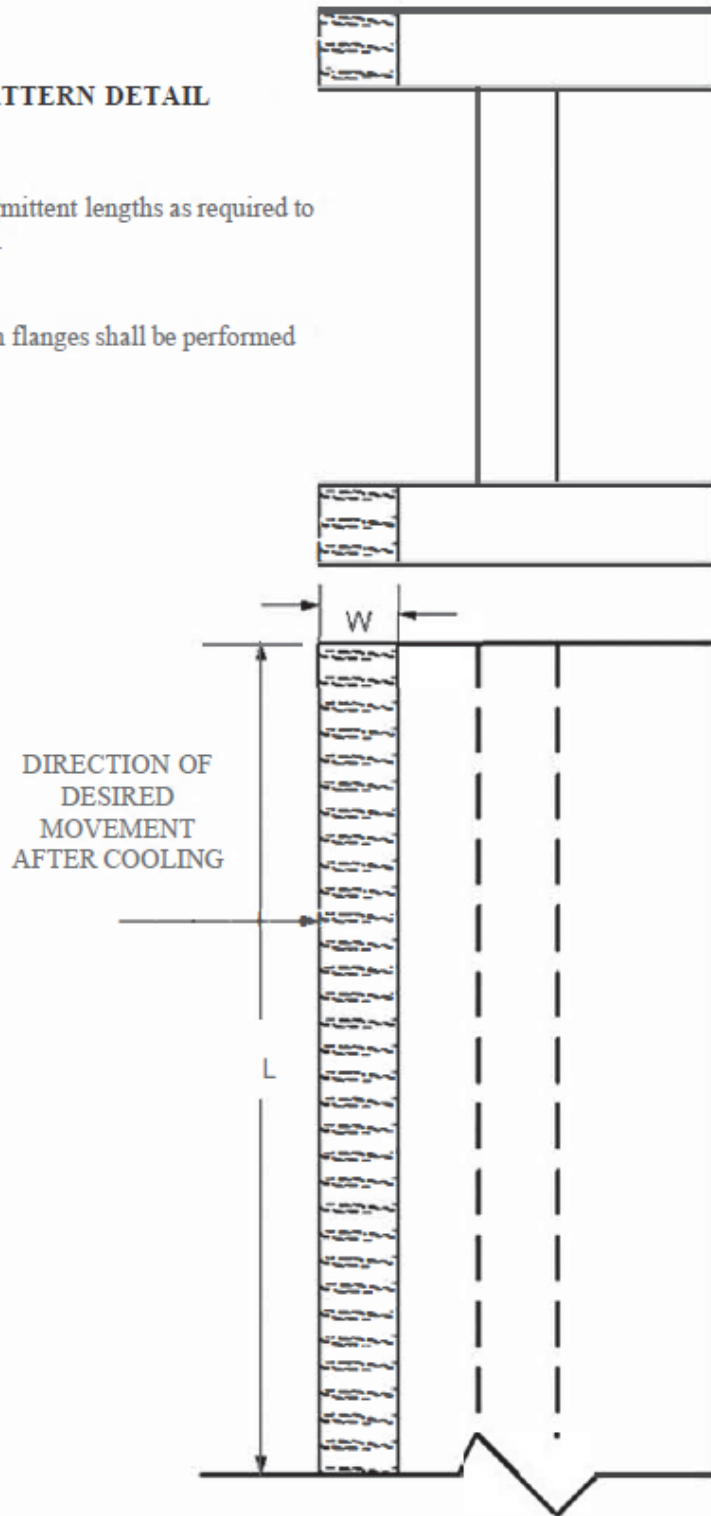

Part 4: Standard Repair Procedures

Table 1 – Recommended torch tips for various material thicknesses

Steel Thickness (in)	Orifice Type	Size
< 1/4	Single	3
3/8	Single	4
1/2	Single	5
5/8	Single	7
3/4	Single	8
1	Single Rosebud	8 3
2	Single Rosebud	8 4
3	Rosebud	5
> 4	Rosebud	5

Part 4: Standard Repair Procedures

08/19

CORRECTING FLANGE TILT OR BEARING SQUARING

Fabricator Name: _____ ECMS #: _____

SR: _____ Sec: _____ County: _____ S- _____

Date: _____ Location on Piece: _____

1. Heat shall be applied to the girder to adjust flange tilt or to square the bearing to meet contractual requirements. Heat **shall not** be applied to previously heated areas.
2. Heating patterns shall be established as required to correct the flange tilt or bearing square condition.
3. Heating shall be performed using an approximately one-inch multi-orifice rosebud tip. Roughly 25 PSI natural gas and 125 PSI oxygen shall be used. Rosebud tip selection shall be made to promote heating efficiency while minimizing distortion and excessive heating to the flange.
4. No mechanical force shall be applied to the flange or web.
5. Heating shall be confined to the planned patterns. The steel shall be brought to a temperature between 1000 °F Fahrenheit and 1150 °F as rapidly as possible. Temperature indicating crayons manufactured to indicate 600, 1100 and 1150 °F shall be utilized. All heat measurements shall be taken after the torch has been removed from the steel. Any heating that results in a steel temperature in excess of 1150 °F shall be considered destructive and be cause for rejection of the steel.
6. Quenching with water or a combination of air and water is not permitted. Cooling with dry compressed air is permitted after the steel has been allowed to cool naturally to 600 °F.
7. Minor polishing may be required to reduce high spots on the outside surface of the bearing area to achieve a flat and smooth condition after heating.
8. Magnetic Particle testing required for the girder shall be performed after all heat correction is completed.
9. All work described above shall be witnessed by PENNDOT inspector and the fabricator's Quality Control personnel. Work shall be performed in accordance with AWS D1.5, AASHTO and the contract specified Publication 408 revision.

Fabricator's Quality Control Representative

PennDOT Inspector Witnessing Procedure

Signature: _____

Signature: _____

Part 4: Standard Repair Procedures

08/19

REPAIR OF ARC STRIKES
For Non-Fracture Critical Applications

Fabricator Name: _____ ECMS #: _____

SR: _____ Sec: _____ County: _____ S- _____

Date: _____ Location on Piece: _____

1. Grind to bright metal to remove the defective area. The excavation shall be smooth and free of irregularities.
2. Magnetic Particle test the area to assure removal of all discontinuities.
3. Weld the defect with a qualified welder, using an approved Weld Procedure Specification when necessary. Grind finished weld smooth and parallel to the direction of applied stress.
4. Magnetic Particle and Ultrasonic testing shall be performed for the repair area.
5. All work shall be performed in the presence of a representative of the Pennsylvania Department of Transportation and the fabricator's Quality Control personnel. Work shall be performed in accordance with AWS D1.5-, AASHTO and the contract specified Publication 408 revision.

Fabricator's Quality Control Representative

PennDOT Inspector Witnessing Procedure

Signature: _____

Signature: _____

08/19

**REPAIR OF GOUGES IN FLAME CUT EDGES FOR
NON-FRACTURE CRITICAL APPLICATIONS**

Fabricator Name: _____ ECMS #: _____

SR: _____ Sec: _____ County: _____ S- _____

Date: _____ Location on Piece: _____

Gouges 3/16 inch or less in Depth

(but not exceeding 2% loss of cross section area)

1. These gouges shall be repaired by grinding in the direction of applied stress in the member.
2. Material shall be faired to the material edge with a slope not to exceed one in ten.

Note: Material defects exposed by thermal cutting shall not be repaired as per this procedure.

Gouges over 3/16" to a maximum of 7/16" deep

(but not exceeding a length of 1 ½ in. parallel to the member)

1. Grind gouge to bright metal with a bottom radius of 1/4 inch minimum and a 20 degree minimum bevel on sides of gouge.
2. Attach run off tabs with no tack welds outside the repair area. Tack welds must be consumed by final weld.
3. Pre-heat to the applicable minimum temperature and maintain interpass temperature.
4. Weld the defect with a qualified welder, using an applicable approved Welding Procedure Specification.
5. Remove run-off tabs and grind surfaces smooth and flush. Final grinding shall be parallel to the longitudinal direction of the flange.
6. Ultrasonic and Magnetic Particle Testing shall be performed on all welded burn gouge repairs to the applicable AWS D-1.5- tension or compression code.
7. All work shall be performed in the presence of a representative of the Pennsylvania Department of Transportation and the fabricator's Quality Control personnel. Work shall be performed in accordance with AWS D1.5, AASHTO and the contract specified Publication 408 revision.

Note: Material defects exposed by thermal cutting will not be repaired as per this procedure.

* **Note:** Approval of these procedures does not supersede any applicable provisions of AASHTO, AWS D1.5- or PennDOT Publication 408.

Part 4: Standard Repair Procedures

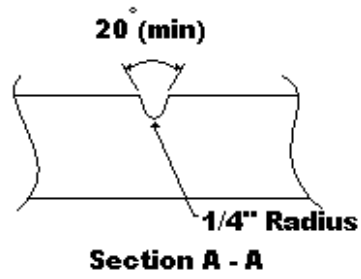
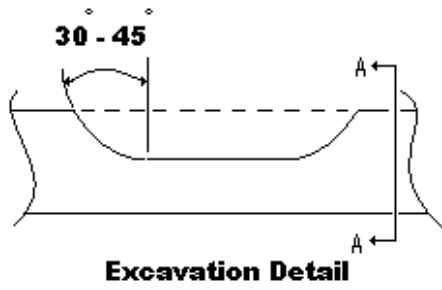

Fabricator's Quality Control Representative

PennDOT Inspector Witnessing Procedure

Signature: _____

Signature: _____

Part 4: Standard Repair Procedures

08/19

STIFFENER REMOVAL PROCEDURE (NON-FCM)

Fabricator Name: _____ ECMS #: _____

SR: _____ Sec: _____ County: _____ S- _____

Date: _____ Location on Piece: _____

The following procedure is to be used to remove and replace stiffeners that have been installed and welded:

1. Remove the stiffener by flame cutting to 1/8 inch above the fillet welds.
2. Using air carbon arc, being extremely careful not to damage the web/flange base metal, remove the weld and remaining stiffener to within 1/8 inch of the base metal. Protect the base metal to prevent damage from spatter.
3. Grind the remaining fillet weld/stiffener smooth and flush with the surrounding base metal. Grind parallel to the direction of applied stress.
4. Magnetic Particle inspect 100% of the weld removal areas.
5. Fit and weld the replacement stiffener at the detailed location and in accordance with the applicable approved Welding Procedure Specification.
6. All work shall be performed in the presence of the Department's Quality Assurance inspector and the fabricator's Quality Control personnel. Work shall be performed in accordance with AWS D1.5, AASHTO and the contract specified Publication 408 revision.

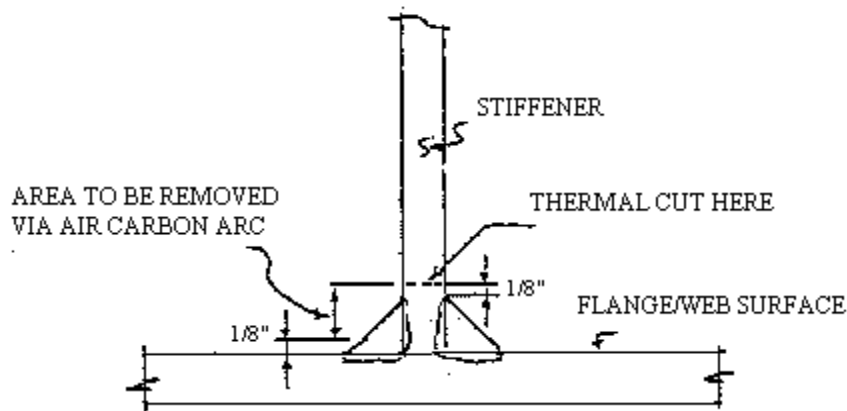

STIFFENER REMOVAL DETAIL

Fabricator's Quality Control Representative

PennDOT Inspector Witnessing Procedure

Signature: _____

Signature: _____

[THIS PAGE IS INTENTIONALLY LEFT BLANK]

APPENDICES

APPENDIX I: QUALITY CONTROL PLAN GUIDELINES

Ensure the fabricator has a current and approved Quality Control Plan that describes the roles, activities and procedures associated with executing the minimum quality control requirements listed herein.

The Quality Control Plan may be maintained in electronic format; however, one or more copies of the plan must be maintained by the fabricator's Quality Control Manager in a printed and bound format (3 ring or other). The Quality Control Plan will be available to all employees. Each document in the plan shall indicate its preparation date and all pages shall be numbered. If a document is revised, the date of revision shall be indicated on the document and recorded in a table of revisions.

The following Quality Control items were adopted from the AASHTO/NSBA Steel Bridge Collaboration, S4.1- 2002 'Steel Bridge Fabrication QC/QA Guide Specification'.

1. Organization

A. Organization, Certification and Qualifications

1. Describe the level of AISC certification and any other applicable certifications. Include copies of the latest certificates in the Quality Control Plan.
2. Provide an organizational chart that establishes functions, duties, responsibilities, position titles, names and lines of authority.
3. Illustrate a separate chain of command from Quality Control to Plant Management/Engineering, independent of Production.
4. Identify any Certified Welding Inspector(s) which will oversee welding.
5. List any independent testing laboratories that will be utilized for testing, inspection or qualification.

2. Inspection and Testing Equipment

A. Describe the method and frequencies for calibration/verification of welding and testing equipment as per the applicable standards.

1. Include any standard forms used.

3. Control of Raw Materials

B. Describe the method(s) used to inspect incoming materials for conformance to the drawings, plans or specifications.

1. Inspections should include verification that no repairs have been performed at the producing mill except grinding or welded repairs as allowed in ASTM A6. Fracture critical materials must not include any welded repairs unless authorized in writing by the Department or Owner.
2. Include any standard forms used.

Appendix I: Quality Control Plan Guidelines

4. Welding Procedures, Consumables, and Welder Qualifications

- A. Describe the procedure for documenting welder qualifications, Weld Procedure Specifications, and Procedure Qualification Records.
 - 1. Include any standard forms used.
 - 2. Utilize only standard PennDOT forms for PQR, WPS and macro-etch submission and testing. Use a unique and traceable identification number for each.
- B. Describe the process(es) for distribution of the approved WPS to the shop floor and use by production/QC during fabrication.
- C. Describe the procedures used to properly store and handle welding consumables of all types. Include methods for fracture critical materials, if applicable. Include the following:
 - 1. Use of approved consumables
 - 2. Warehouse storage, including inventory and stock rotation
 - 3. Storage in the fabrication shop
 - 4. Procedures for holding and redrying SMAW electrodes
 - 5. Control for time out of storage oven for SMAW electrodes
 - 6. Drying and recycling of SAW flux
 - 7. Storage of SAW flux and electrodes
 - 8. Storage and moisture control for FCAW electrodes
 - 9. Storage of GMAW electrodes

5. Coatings (If applicable)

- A. Describe the plant's level of AISC/SSPC paint certification and any other applicable certifications.
 - 1. Include copies of the latest certificates in the Quality Control Plan.
- B. Describe methods and or procedures used to verify, control and or document the following items which are documented. Include standard forms used:
 - 1. Oil/moisture in air lines
 - 2. Mixing and agitation
 - a. Monitoring pot life
 - b. Ambient and steel temperature
 - c. Relative humidity
 - d. Dew point
 - e. Cure assessment
 - f. Wet film / dry film thickness
 - g. Repairs for damage, dry spray, runs, sags and under/over thickness

6. Nondestructive Examination (NDE)

Appendix I: Quality Control Plan Guidelines

- A. Submit the written practice used to control and qualify each NDE method employed. The written practice must meet the requirements of ASNT-SNT-TC-1A.
- B. Identify the certified ASNT Level III personnel for each method.
- C. Identify any ASNT Level II certified employees.
- D. Identify any ASNT Level I certified employees and the Level II supervisor.

Note: When third party services are used for NDE, obtain a copy of that company's ASNT SN-TC-1A written practice and include within the Quality Control Manual.

7. Nonconformance Control

- A. Describe the methods and procedures for identifying, controlling and disposing of nonconforming materials.
- B. Describe procedures for submitting repair procedures to the Department for approval. The following minimum criteria must be included.
 - 1. ECMS #, State Route, Section and County
 - 2. Piece mark, type, size, location and cause (if known) of the defect
 - 3. Proposed method(s) for correcting the defect
 - 4. NDT method(s) to be utilized

APPENDIX II: LOCATION FOR INSPECTION STAMP

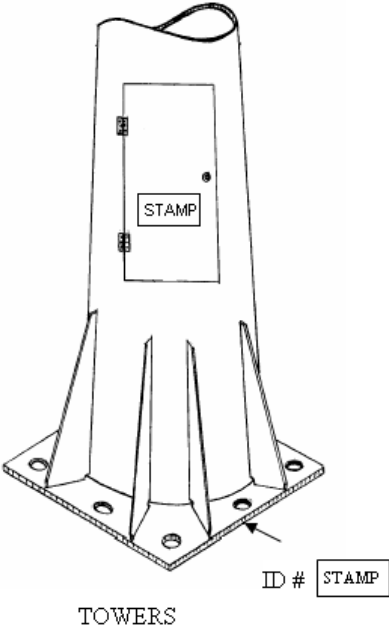
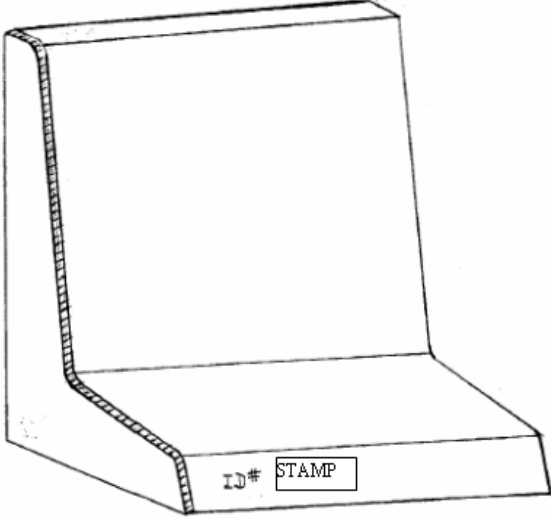
Item	Stamp Frequency	Approx. Location of Stamp	Sketch
Sign Structure Tower	Each Tower	Place one stamp on the bottom of the base plate of each tower and one stamp on the inside hand hole cover for each tower when a hand hole is present.	 <p>The sketch shows a tall, narrow tower with a wide base plate. A rectangular stamp labeled 'STAMP' is positioned on the front face of the tower. Below the tower, the word 'TOWERS' is written. To the right, an arrow points to a stamp labeled 'ID #' and 'STAMP' on the base plate.</p>
Slider Plate	Each Plate	Place one stamp next to the Fabricators' ID number for each plate.	 <p>The sketch shows a U-shaped slider plate. A stamp labeled 'ID #' and 'STAMP' is located on the bottom edge of the plate. Below the sketch, the words 'SLIDER PLATE' are written.</p>

Appendix II: Location For Inspection Stamp

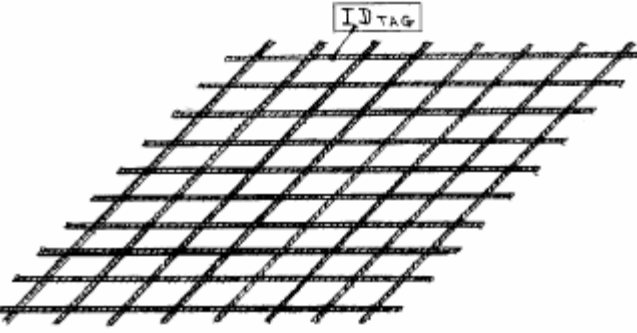
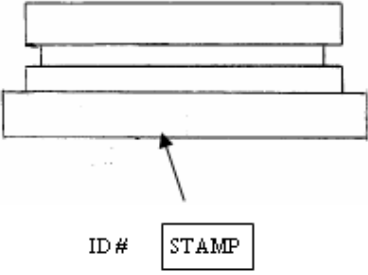
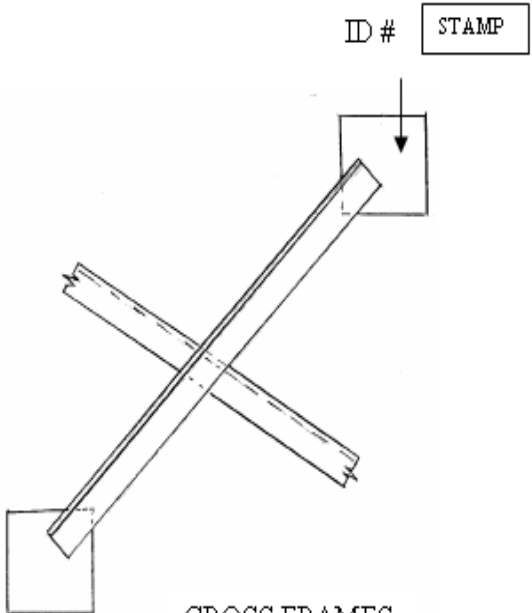
Item	Stamp Frequency	Approx. Location of Stamp	Sketch
Grid Flooring	Each Section	Place one stamp on the ID tag for each section of grid flooring.	 <p>The sketch shows a perspective view of a grid of horizontal and vertical lines representing grid flooring. A small rectangular box labeled 'ID TAG' is positioned at the top center of the grid. Below the grid, the text 'GRID FLOORING' is centered.</p>
Bearing	Each Bearing	Place one stamp next to the ID number for each bearing.	 <p>The sketch shows a side view of a bearing assembly consisting of three stacked cylindrical components. Below the assembly, the text 'ID #' is followed by a rectangular box labeled 'STAMP'. An arrow points from the 'STAMP' box to the side of the bottom-most bearing component. Below the sketch, the text 'BEARING' is centered.</p>
Cross Frames	Each Cross Frame	Place one stamp for each cross frame next to the ID number on the flat plate face.	 <p>The sketch shows two long, narrow rectangular bars crossing each other at an angle to form an 'X' shape. A rectangular box labeled 'ID #' is positioned above the intersection. Below it, another rectangular box labeled 'STAMP' has an arrow pointing to the flat surface of one of the bars. Below the sketch, the text 'CROSS FRAMES' is centered.</p>

Appendix II: Location For Inspection Stamp

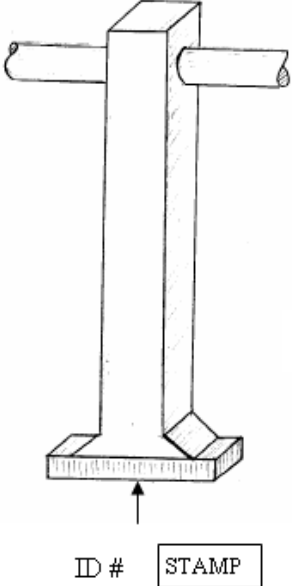
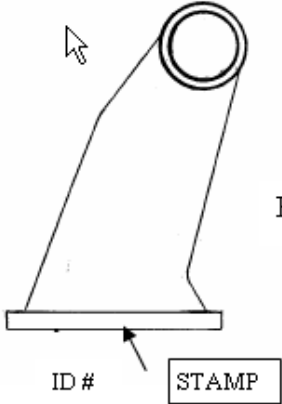
Item	Stamp Frequency	Approx. Location of Stamp	Sketch
Railings Post	Each Post	Place one stamp next to the ID number for each railing post.	 <p>The sketch shows a vertical railing post with two horizontal rails. An arrow points to the base of the post, labeled 'ID #'. A box labeled 'STAMP' is positioned to the right of the 'ID #' label.</p> <p>RAILINGS POST</p>
Railing Post	Each post	Place one stamp next to the ID number for each railing post.	 <p>The sketch shows a railing post with a circular top. An arrow points to the base of the post, labeled 'ID #'. A box labeled 'STAMP' is positioned to the right of the 'ID #' label.</p> <p>RAILING POST</p>

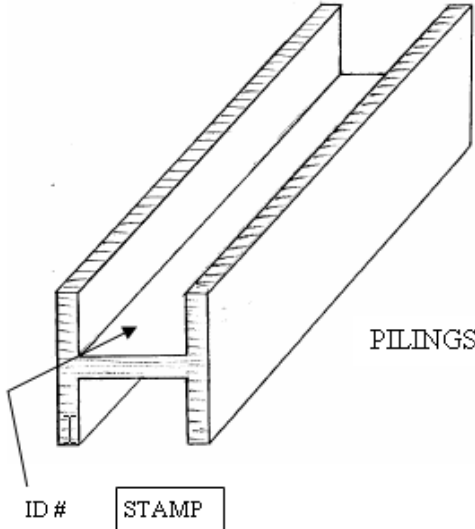
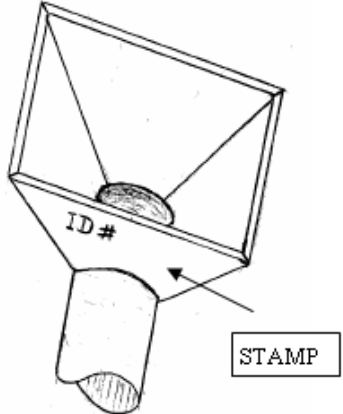

Appendix II: Location For Inspection Stamp

Item	Stamp Frequency	Approx. Location of Stamp	Sketch
Pilings	Each Pile	Place one stamp on the web face next to the ID number for each pile.	 <p>The sketch shows two parallel pilings. An arrow points to the web face of the front piling, where the text 'ID #' is written. A box labeled 'STAMP' is positioned next to the ID number. The word 'PILINGS' is written to the right of the objects.</p>
Drainage Item	Each Assembly	Place one stamp next to the ID number for each drainage assembly.	 <p>The sketch shows a funnel-shaped drainage item. An arrow points to the side of the funnel where the text 'ID #' is written. A box labeled 'STAMP' is positioned next to the ID number. The words 'DRAINAGE ITEM' are written below the object.</p>

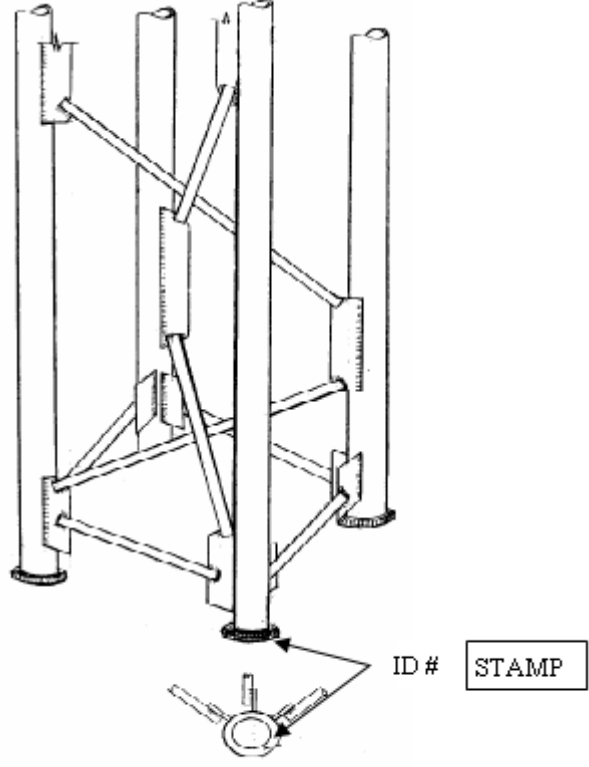
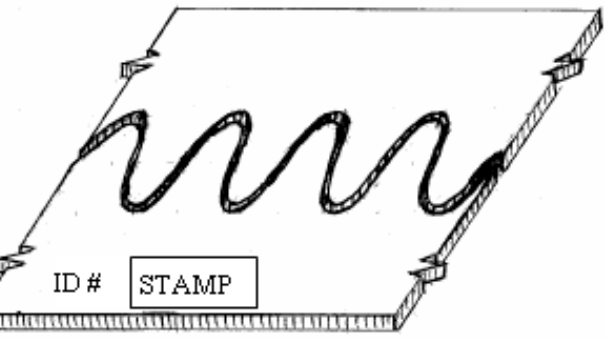

Appendix II: Location For Inspection Stamp

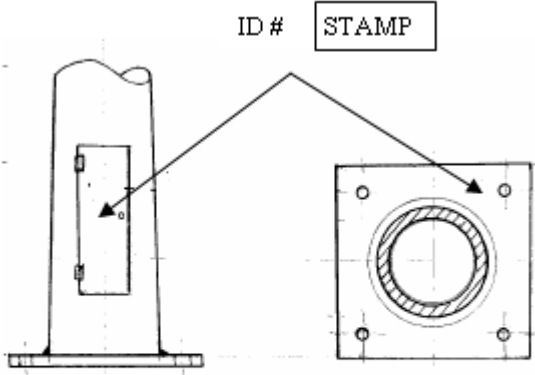
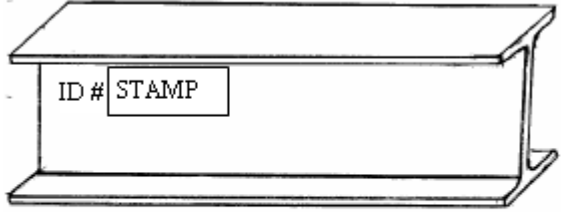
Item	Stamp Frequency	Approx. Location of Stamp	Sketch
Sign Structures	Each Section	Place one stamp next to the ID number on the splice plate for each truss section.	 <p data-bbox="850 1079 1122 1108">SIGN STRUCTURE</p>
Tooth Expansion Dams	Each Piece	Place one stamp next to the ID number for each expansion dam.	 <p data-bbox="867 1612 1287 1642">TOOTH EXPANSION DAMS</p>

Appendix II: Location For Inspection Stamp

Item	Stamp Frequency	Approx. Location of Stamp	Sketch
Light Poles	Each Pole	Place one stamp on the bottom of the base plate of each tower and one stamp on the inside hand hole cover for each tower when a hand hole is present.	 <p style="text-align: center;">LIGHT POLES</p>
Girders and Stringers	Each Girder or Stringer	Place one stamp on the nearside web face next to the ID number for each girder or stringer.	 <p style="text-align: center;">GIRDERS & STRINGERS</p>
Misc. pieces Boxed, canned or pallet	Each	Place where practical due to the number of miscellaneous parts, one stamp on each ID Tag, or each individually packaged item and on the outside surface of each box, can, or pallet.	 <p style="text-align: center;">MISCELLANEOUS PARTS</p>

Appendix II: Location For Inspection Stamp

Item	Stamp Frequency	Approx. Location of Stamp	Sketch
Miscellaneous Sub-assemblies bundled and strapped	Each	Place one stamp on each ID Tag to be visible after bundling	
Miscellaneous Sub-assemblies bundled and boxed	Each	See above. Also stamp the exterior of the box	

APPENDIX III: NON-DESTRUCTIVE TEST CERTIFICATION REQUIREMENTS

The Inspector assigned to a plant with the primary work type must possess the CWI and NDT Level II certification as shown below. Exceptions must be requested by the consultant project manager in advance of the work assignment.

Primary Work Type (Specific experience for inspection personnel other than structural steel fabrication noted where applicable)		CWI (R-Required; P-Preferred)	NDT Level II Requirement
Steel Structures Production	Girder / Rolled Beams	R	MT, UT, [RT] ⁽³⁾ , Visual
	Dams ⁽¹⁾	R	MT, UT, Visual
	Steel Railing	R	MT, UT, Visual
	Steel Sign Structures	R	MT, UT, [RT] ⁽³⁾ , Visual
	Bearings ⁽¹⁾	R	MT, UT, PT, Visual
	Steel Light Poles	R	MT, UT, [RT] ⁽³⁾ , Visual
	Steel Guide Rail Post	R	MT, Visual
	Pedestrian Bridge	R	MT, UT, Visual
	Steel Barrier	R	MT, UT, Visual
All Production	Machining	P	Visual
Aluminum Production	Aluminum Barrier ⁽²⁾	R	PT, [UT] ⁽³⁾ , Visual
	Aluminum Light Poles ⁽²⁾	R	PT, [RT] ⁽³⁾ , Visual
	Aluminum Railing ⁽²⁾	R	PT, [UT] ⁽³⁾ , Visual
Coatings	Metalizing	P	Visual
	Galvanizing	P	Visual
	Paint	P	Visual

- (1) Experience in Stainless Steel fabrication preferred (indicate in resume)
- (2) Experience in Aluminum fabrication required (indicate in resume)
- (3) NDE certification preferred but not required unless specifically indicated

APPENDIX IV: ADVANCED ULTRASONIC EXAMINATION (PHASED ARRAY ULTRASONIC TESTING)

Editor's Note: The requirements listed as part of American Welding Society D1.5 2015 Annex K are not all inclusive. Additional and most current Best Practices are to be utilized.

At a minimum, all items outlined in Annex K and listed below require a formal submission to the SME for review and approval prior to the use of Advanced Ultrasonic Examination NDT techniques.

- All current and future research studies and technology briefings are to be considered and utilized where practicable and when directed by the SME.
 - Procedure considerations must include but will not be limited to the following:
 - Direction of Roll
 - Beam Angle
 - Probe Frequency
 - Material
 - Joint geometry
 - Mockup verification
 - Calibration material for material type, thickness and geometry
- As noted in AWS D1.5 Annex K, all techniques require written procedures, advanced operator training and qualification, and calibration methods specific to PAUT.
- Documentation and Reporting: In addition to AWS D1.5 Annex K, Section K13, all PAUT performed for the Department shall include all raw data generated by the PAUT Process. Digital submissions are required in a format that is acceptable to the SME. When required, supplemental software required for evaluation by the Department is to be supplied by the fabricator.
- Transfer of the raw data and digital report to the Department must be performed in the most efficient methods and as directed by the Department.
- All raw data and digital reports must be retained by the fabricator according to AWS D1.5 Section 6.12.3 and for a minimum of 3 years after the completion of the project.
- Advanced Ultrasonic Examination In lieu of Radiographic Testing must be approved by the SME prior to its use.
- PAUT is not permitted for ESW.

[THIS PAGE IS INTENTIONALLY LEFT BLANK]